



**VARITRONIX**

VL-PS-COG-BCD12864-02 REV.A

(COG-BCD12864)

NOV/2007

PAGE 1 OF 14

DOCUMENT NUMBER AND REVISION

**VL-PS-COG-BCD12864-02 REV.A**

**(COG-BCD12864)**

DOCUMENT TITLE:

**PRELIMINARY SPECIFICATION**

**OF**

**LCD MODULE TYPE**

**MODULE NUMBER: COG-BCD12864-02**

DEPARTMENT	NAME	SIGNATURE	DATE
PREPARED BY	LINDA ZHU	Linda Zhu	2007.11.15
CHECKED BY	GAO KE QIANG	GaoKeQiang	2007/11/15
APPROVED BY	LAW YING LEUNG	YLL	2007/11/15

DISTRIBUTION LIST: MARKETING



**DOCUMENT REVISION HISTOR**

DOCUMENT REVISION FROM TO	DATE	DESCRIPTION	CHANGED BY	CHECKED BY
A	2007.11.13	First Release.	LINDA ZHU	GAO KE QIANG

## **CONTENTS**

		<u>Page No.</u>
1.	TECHNOLOGY DESCRIPTION	4
2.	TYPICAL APPLICATIONS	4
3.	GENERAL DESCRIPTION	4
4.	MECHANICAL SPECIFICATIONS	5
5.	INTERFACE SIGNALS	8
6.	ABSOLUTE MAXIMUM RATINGS	9
6.1	ELECTRICAL MAXIMUM RATINGS – FOR IC ONLY	9
6.2	ENVIRONMENTAL CONDITION	9
7.	ELECTRICAL SPECIFICATIONS	10
7.1	TYPICAL ELECTRICAL CHARACTERISTICS	10
7.2	TIMING SPECIFICATIONS	11
7.3	TEMPERATURE COMPENSATION	12
8.	OPTICAL CHARACTERISTICS AT 25°C	12
8.1	OPTICAL CHARACETRISTICS DEFINITION	13
8.1.1	VIEW ANGLE	13
8.1.2	CONTRAST RATIO	13
9.	LCD COSMETIC CONDITIONS	13
10.	REMARK	14

---

## **VARITRONIX LIMITED**

---

**Preliminary Specification  
of  
LCD Module Type  
Model No.: COG-BCD12864-02**

### **1. Technology Description**

BCD (Bi-stable Cholesteric Display) is a sunlight readable reflective LCD with extremely low power consumption characteristics. Due to the non-volatile memory feature of the technology, zero power is required to retain the image of the display. Energy is only required to change the displayed image. No backlighting is required, only ambient lighting from the surrounding is required. Readability when under direct sunlight is excellent and good contrast from viewing at very wide angles are possible.

### **2. Typical Applications**

This module is intended for general purpose graphic and character display applications. Suggested uses include instrumentation, remote control, electronic product or price label, point of sale display, general purpose indoor or outdoor signage and information display.

### **3. General Description**

- Passive matrix bistable cholesteric display, Positive, reflective LCD graphic module
- Color: Blue & White
- Display resolution: 128 x 64 dots
- Viewing angle: all angles (for inclinations of  $<70^\circ$ ,  $CR > 3$ )
- "VL1001" 4-wires Serial Interface LCD Controller/Drivers.
- Driving scheme: Special BCD driving scheme
- Logic voltage: +3.3 V
- FPC connection
- The module does not contain polarizer and the customer is recommended to add a UV cut filter (98% blocking of 380nm and lower spectral components)
- The module is licensed by Kent Display Systems



#### 4. Mechanical Specifications

The mechanical detail is shown in Fig. 1 and summarized in Table 1 below.

Table 1

Parameter	Specifications	Unit
Outline dimensions	66.0(W) x 43.4(H) x 1.4(D) (Exclude FPC) 66.0(W) x 78.4(H) x 1.4(D) (Include FPC)	mm
Viewing area	61.0(W) x 31.4 (H)	mm
Active area	55.025(W) x 27.505(H)	mm
Display format	128(Horizontal) x 64(Vertical)	dots
Dot size	0.415(W) x 0.415(H)	mm
Dot spacing	0.015(W) x 0.015(H)	mm
Dot pitch for characters	0.43(W) x 0.43(H)	mm
Weight	TBD	gram

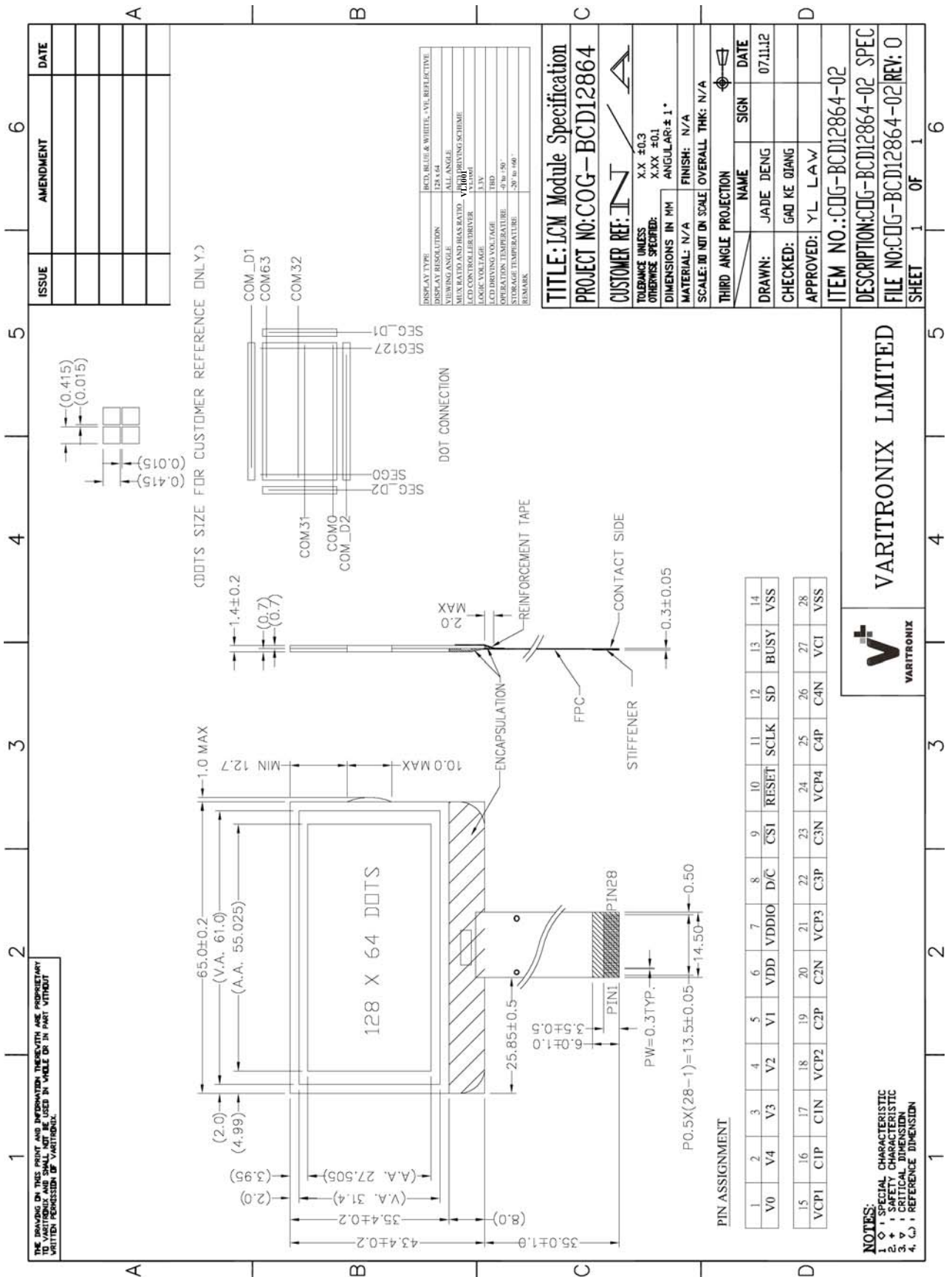

Figure 1: Module Specification

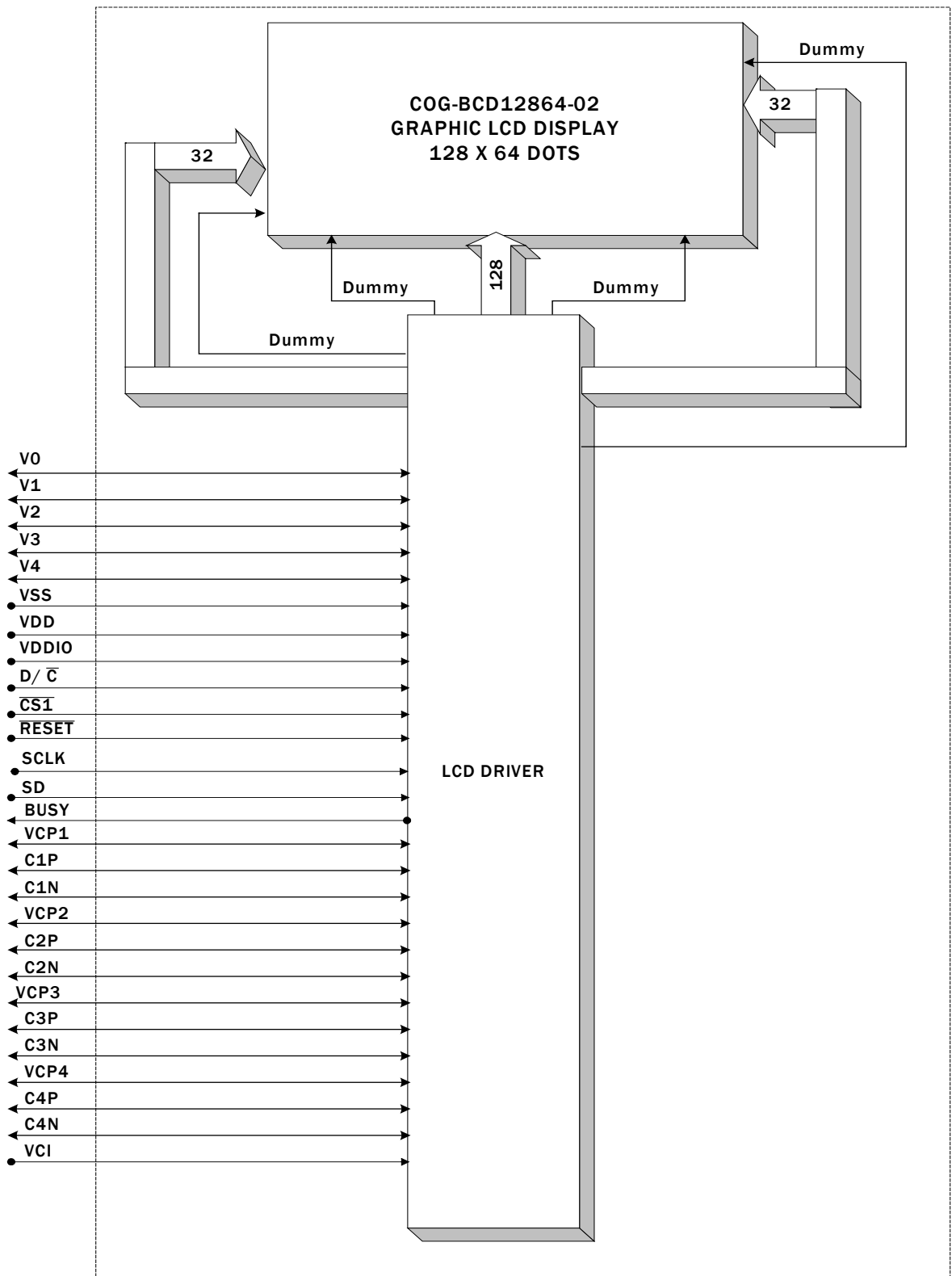

Figure 2: Block Diagram

## 5. Interface Signals

Table 2

Pin No.	Symbol	Description
1	V0	It is the high voltage power input pin and panel driving voltage. It should be connected to VCP1
2	V4	Panel driving voltage. If bias divider is enabled with the presence of V0. The voltage is equal to $1/N * V0$ , where N is equal to the Bias ratio Setting
3	V3	Panel driving voltage. If bias divider is enabled with the presence of V0. The voltage is equal to $2/N * V0$ , where N is equal to the Bias ratio Setting.
4	V2	Panel driving voltage. If bias divider is enabled with the presence of V0. The voltage is equal to $(N-2)/N * V0$ , where N is equal to the Bias ratio Setting.
5	V1	Panel driving voltage. If bias divider is enabled with the presence of V0. The voltage is equal to $(N-1)/N * V0$ , where N is equal to the Bias ratio Setting.
6	VDD	This pin is the system power supply pin of the logic block.
7	VDDIO	Power supply for interface logic level. It should match with the MCU interface voltage level. It must always be equal or lower than VDD.
8	D/ $\bar{C}$ (D/C#)	This pin is Data/Command control pin. A high at D/C indicates data input while a low at D/C indicates command input.
9	$\bar{CS1}$ (CS1#)	These pins are the chip select inputs for communication between MCU. To select the chip CS1# must be low and CS2 must set high. For serial mode, it is needed to select the chip which CS1# must be low and CS2 must set high.
10	$\overline{RESET}$ (RES#)	This pin is the reset signal input. Initialization of the chip is started once this pin is pulled low. Minimum pulse width for reset sequence is 20us.
11	SCLK	In serial interface mode, D1 is the serial data input (SD <sub>IN</sub> ), D0 is the serial clock input, (SCLK).
12	SD	
13	BUSY	A high level indicates busy status (output driving waveform) of the driver.
14	VSS	Ground.
15	VCP1	DC/DC output voltage. Connect with a capacitor to VSSC. It should be connected to V0.
16	C1P	DC/DC flying capacitor terminal. Connect a capacitor between C1N and C1P.
17	C1N	
18	VCP2	DC/DC intermediate output voltage. Connect with a capacitor to VSSC. If using external mode with HV buffer enabled, it should be connected to V0.
19	C2P	DC/DC flying capacitor terminal. Connect a capacitor between C2N and C2P.
20	C2N	
21	VCP3	DC/DC intermediate output voltage. Connect with a capacitor to VSSC
22	C3P	DC/DC flying capacitor terminal. Connect a capacitor between C3N and C3P.
23	C3N	
24	VCP4	DC/DC intermediate output voltage. Connect with a capacitor to VSSC.
25	C4P	DC/DC flying capacitor terminal. Connect a capacitor between C4N and C4P.
26	C4N	
27	VCI	Power supply for DC-DC converter and analog part of the chip. It should be connected to VDD.
28	VSS	Ground.

## 6. Absolute Maximum Ratings

### 6.1 Electrical Maximum Ratings-For IC Only

Table 3

Parameter	Symbol	Conditions	Min.	Max.	Unit
Supply voltage	$V_{DD}$	TA = +25°C, Referenced to VSS = 0V	-0.3	+3.6	V
	$V_{DDIO}$		-0.3	Min ( $V_{DD}+0.5$ , +3.6)	V
	$V_0$		-0.3	+38	V
	$V_{CI}$		-0.3	+3.6	V
Input voltage	$V_{in}$		$V_{ss} - 0.3$	$V_{DDIO} + 0.3$	V

Note1: TA = +25°C.

Note2: The maximum applicable voltage on any pin with respect to VSS (0V).

Note3: The modules may be destroyed if they are used beyond the absolute maximum ratings.

### 6.2 Environmental Condition

Table 4

Item	Operating temperature (Topr)		Storage temperature (Tstg) (Note 1)		Remark
	Min.	Max.	Min.	Max.	
Ambient temperature	0°C	+50°C	-20°C	+60°C	Dry
Humidity (Note 1)	90% max. RH for Ta ≤ 40°C < 50% RH for 40°C < Ta ≤ Maximum operating temperature				No condensation
Vibration (IEC 68-2-6) cells must be mounted on a suitable connector	Frequency: 10 ~ 55 Hz Amplitude: 0.75 mm Duration: 20 cycles in each direction.				3 directions
Shock (IEC 68-2-27) Half-sine pulse shape	Pulse duration: 11 ms Peak acceleration: 981 m/s <sup>2</sup> = 100g Number of shocks: 3 shocks in 3 mutually perpendicular axes.				3 directions

Note 1: Product cannot sustain at extreme storage conditions for long time.

## 7. Electrical Specifications

### 7.1 Typical Electrical Characteristics

At  $T_a = 25\text{ }^\circ\text{C}$ ,  $V_{DD} = +3.3\text{V} \pm 10\%$ ,  $V_{SS} = 0\text{V}$ .

Table 5

Parameter	Symbol	Conditions	Min.	Typ.	Max.	Unit
Supply voltage (Logic)	$V_{DD-VSS}$		-	3.3	-	V
Input signal voltage low	$V_{IL}$		0	-	$0.2V_{DDIO}$	V
Input signal voltage high	$V_{IH}$		$0.8V_{DDIO}$	-	$V_{DDIO}$	V
Supply current (Logic & LCD)	$I_{DD}$	$V_{DD}=3.3\text{V}$	-	TBD	-	mA

## 7.2 Timing Specifications

At  $T_a = +25\text{ }^\circ\text{C}$ ,  $V_{DD} = V_{CI} = V_{DDIO} = +3.3\text{V} \pm 10\%$

Table 6

Symbol	Parameter	Min	Typ	Max	Unit
$t_{cycle}$	Clock Cycle Time	60	-	-	ns
$t_{AS}$	Address Setup Time	10	-	-	ns
$t_{AH}$	Address Hold Time	20	-	-	ns
$t_{DSW}$	Write Data Setup Time	30	-	-	ns
$t_{DHW}$	Write Data Hold Time	30	-	-	ns
$T_{CLKL}$	Clock Low Time	30	-	-	ns
$T_{CLKH}$	Clock High Time	30	-	-	ns
$t_{CSS}$	Chip Select Setup Time (for D7 input)	30	-	-	ns
$t_{CSH}$	Chip Select Hold Time (for D0 input)	30	-	-	ns
$t_R$	Rise Time	-	-	10	ns
$t_F$	Fall Time	-	-	10	ns

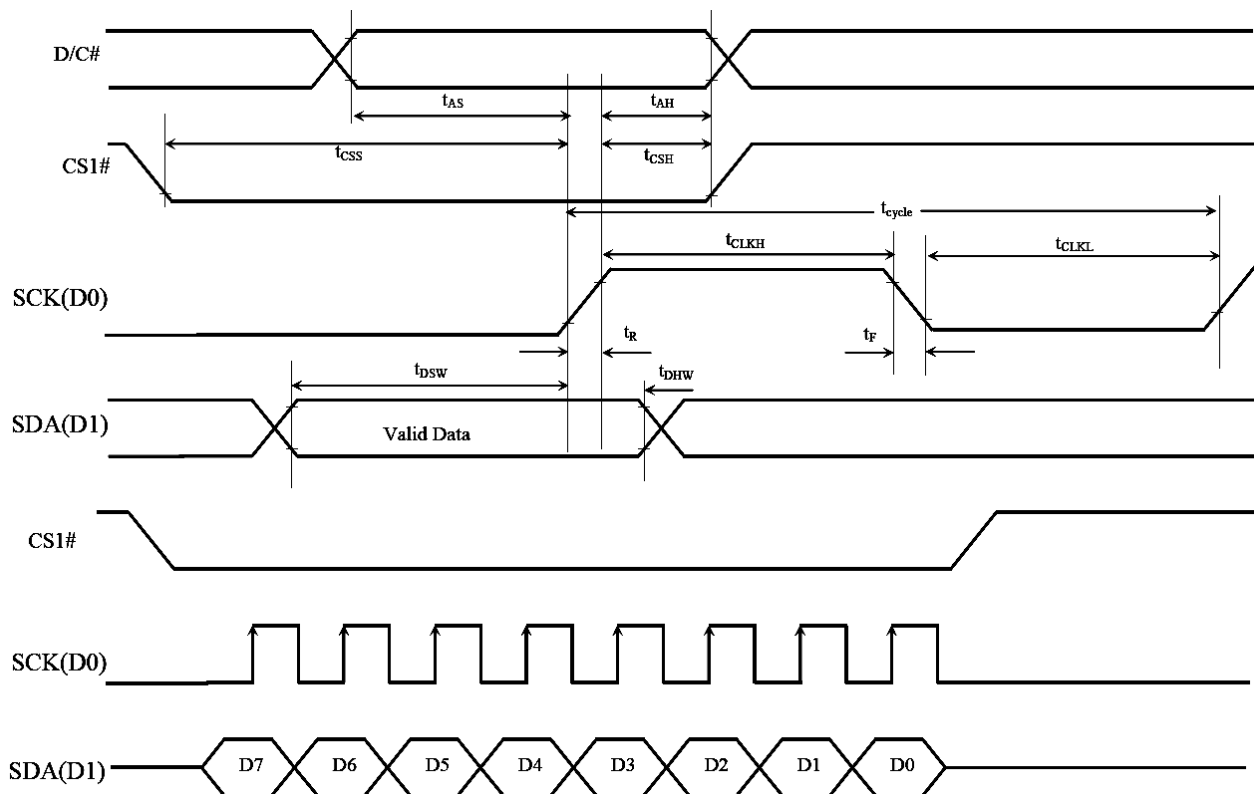

Figure 3: Timing characteristic of 4-wires Serial Interface

### 7.3 Temperature Compensation

Table 7: TC Table

Temperature (°C)	T-reset (ms)	T-select (ms)
-30	4000	2000
-25	2000	750
-20	1000	350
-15	750	250
-10	350	150
0	150	80
≥10	100	20 or more

### 8. Optical Characteristics at 25°C

Table 8

Item	Symbol	Value			Unit	Condition	
		Min.	Typ.	Max.			
Scanning time	-	-	30ms	-	sec	VDD=3.3V, VLCD =30V, @25°C	
Reflectance	-	-	TBD	-	%	-	
Contrast ratio	CR	-	TBD	-	-	-	
Optimum viewing area Cr ≥ TBD	θ1(6 o'clock)	-	TBD	-	DEG	φ = 0°	Vop= Optimum voltage (Remark 1)
	θ2(12 o'clock)	-	TBD	-			
	φ1(3 o'clock)	-	TBD	-		θ = 0°	
	φ2(9 o'clock)	-	TBD	-			

## 8.1 Optical Characteristics Definition

### 8.1.1 Viewing Angle

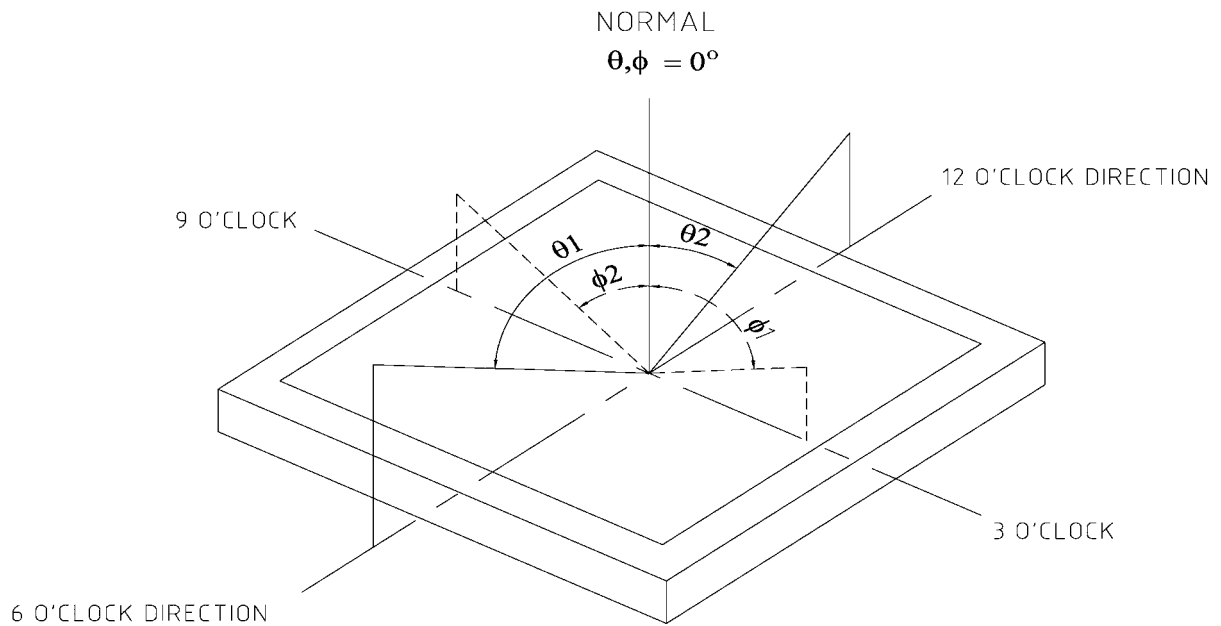

Figure 4

### 8.1.2 Contrast Ratio

B1 = pixel luminance at stable dark state  
 B2 = pixel luminance at stable bright state  
 Contrast Ratio =  $B2/B1$

## 9. LCD Cosmetic Conditions

- a.) Reference document follow TBD.
- b.) LCD size of the product is TBD.

## 10. Remark

### HANDLING LCD AND LCD MODULES

#### 1. Liquid Crystal Display (LCD)

LCD is made up of glass, organic sealant, organic fluid and polymer based polarizers. The following precautions should be taken when handling:

- (1) Keep the temperature within range for use and storage. Excessive temperature and humidity could cause polarization degradation, polarizer peel-off or bubble generation. When storage for a long period over 40° C is required, the relative humidity should be kept below 60%.
- (2) Do not contact the exposed polarizers with anything harder than an HB pencil lead. To clean dust off the display surface, wipe gently with cotton, chamois or other soft material soaked in petroleum benzin. Never scrub hard.
- (3) Varitronix does not responsible for any polarizer defect after the protective film has been removed from the display
- (4) Wipe off saliva or water drops immediately. Contact with water over a long period of time may cause polarizer deformation or color fading, while an active LCD with water condensation on its surface will cause corrosion of ITO electrodes.
- (5) PETROLEUM BENZIN is recommended to remove adhesives used to attach front/rear polarizers and reflectors, while chemicals like acetone, toluene, ethanol and isopropyl alcohol will cause damage to the polarizer. Avoid oil and fats. Avoid lacquer and epoxies which might contain solvents and hardeners to cause electrode erosion. Some solvents will also soften the epoxy covering the DIL pins and thereby weakening the adhesion of the epoxy on glass. This will cause the exposed electrodes to erode electrochemically when operating in high humidity and condensing environment.
- (6) Glass can be easily chipped or cracked from rough handling, especially at corners and edges.
- (7) Do not drive LCD with DC voltage.
- (8) When soldering DIL pins, avoid excessive heat and keep soldering temperature between 260°C to 300°C for no more than 5 seconds. Never use wave or reflow soldering.

#### 2. Liquid Crystal Display Modules (MDL)

##### 2.1 Mechanical Considerations

MDL's are assembled and adjusted with a high degree of precision. Avoid excessive shocks and do not make any alterations or modifications. The following should be noted.

- (1) Do not tamper in any way with the tabs on the metal frame.
- (2) Do not modify the PCB by drilling extra holes, changing its outline, moving its components or modifying its pattern.
- (3) Do not touch the elastomer connector (conductive rubber), especially when inserting an EL panel.

- (4) When mounting a MDL make sure that the PCB is not under any stress such as bending or twisting. Elastomer contacts are very delicate and missing pixels could result from slight dislocation of any of the elements.
- (5) Avoid pressing on the metal bezel, otherwise the elastomer connector could be deformed and lose contact, resulting in missing pixels.
- (6) If FPCA need to be bent, please refer the suggested bending area on the specification. The stiffener and component area on FPC/FPC/COF must not be bent during or after assembly (Note: for those models with FPC/FPC/COF +stiffener).
- (7) Sharp bending should be avoided on FPC to prevent track cracking.

##### 2.2 Static Electricity

MDL contains CMOS LSI's and the same precaution for such devices should apply, namely:

- (1) The operator should be grounded whenever he comes into contact with the module. Never touch any of the conductive parts such as the LSI pads, the copper leads on the PCB and the interface terminals with any part of the human body.
- (2) The modules should be kept in antistatic bags or other containers resistant to static for storage.
- (3) Only properly grounded soldering irons should be used.
- (4) If an electric screwdriver is used it should be well grounded and shielded from commutator sparks.
- (5) The normal static prevention measures should be observed for work clothes and working benches; for the latter conductive (rubber) mat is recommended.
- (6) Since dry air is inductive to statics, a relative humidity of 50 - 60% is recommended.

##### 2.3 Soldering

- (1) Solder only to the I/O terminals.
- (2) Use only soldering irons with proper grounding and no leakage.
- (3) Soldering temperature is 280°C ± 10°C .
- (4) Soldering time: 3 to 4 seconds.
- (5) Use eutectic solder with resin flux fill.
- (6) If flux is used, the LCD surface should be covered to avoid flux spatters. Flux residue should be removed afterwards.
- (7) Use proper de-soldering methods (e.g. suction type desoldering irons) to remove lead wires from the I/O terminals when necessary. Do not repeat the soldering/ desoldering process more than three times as the pads and plated through holes may be damaged.

##### 2.4 Label

Identification labels will be stuck on the module without

obstructing the viewing area of display.

#### 3. Operation

- (1) The viewing angle can be adjusted by varying the LCD driving voltage  $V_0$ .
- (2) Driving voltage should be kept within specified range, excess voltage shortens display life.
- (3) Response time increases with decrease in temperature.
- (4) Display may turn black or dark Blue at temperatures above its operational range; this is however not destructive and the display will return to normal once the temperature falls back to range.
- (5) Mechanical disturbance during operation (such as pressing on the viewing area) may cause the segments to appear "fractured". They will recover once the display is turned off.
- (6) Condensation at terminals will cause malfunction and possible electrochemical reaction. Relative humidity of the environment should therefore be kept below 60%.
- (7) Display performance may vary out of viewing area. If there is any special requirement on performance out of viewing area, please consult Varitronix.

#### 4. Storage and Reliability

- (1) LCD's should be kept in sealed polyethylene bags while MDL's should use antistatic ones. If properly sealed, there is no need for desiccant.
- (2) Store in dark places and do not expose to sunlight or fluorescent light. Keep the temperature between 0°C and 35°C and the relative humidity low. Please consult VARITRONIX for other storage requirements.
- (3) Water condensation will affect reliability performance of the display and is not allowed.
- (4) Semi-conductor device on the display is sensitive to light and should be protected properly.
- (5) Power up/down sequence.
  - a) Power Up: in general, LCD supply voltage,  $V_0$  must be supplied after logic voltage, VDD becomes steady. Please refer to related IC data sheet for details.
  - b) Power Down: in general, LCD supply voltage,  $V_0$  must be removed before logic voltage, VDD turns off. Please refer to related IC data sheet for details.

#### 5. Safety

If any fluid leaks out of a damaged glass cell, wash off any human part that comes into contact with soap and water. Never swallow the fluid. The toxicity is extremely low but caution should be exercised at all times.

### LIMITED WARRANTY

VARITRONIX LCDs and modules are not consumer products, but may be incorporated by VARITRONIX's customers into consumer products or components thereof. VARITRONIX does not warrant that its LCDs and components are fit for any such particular purpose.

1. The liability of VARITRONIX is limited to repair or replacement on the terms set forth below. VARITRONIX will not be responsible for any subsequent or consequential events or injury or damage to any personnel or user including third party personnel and/or user.

Unless otherwise agreed in writing between VARITRONIX and the customer, VARITRONIX will only replace or repair any of its LCD which is found defective electrically or visually when inspected in

accordance with VARITRONIX LCD Acceptance Standards (copies available on request), for a period of one year from the date of shipment. Confirmation of such date shall be based on freight documents.

2. No warranty can be granted if any of the precautions stated in HANDLING LCD and LCD Modules above have been disregarded. Broken glass, scratches on polarizers, mechanical damages as well as defects that are caused by accelerated environmental tests are excluded from warranty.
3. In returning the LCD and Modules, they must be properly packaged and there should be detailed description of the failures or defects.

### IMPORTANT NOTICE

The information presented in this document has been carefully checked and is believed to be accurate, however, no responsibility is assumed for inaccuracies. VARITRONIX reserves the right to make changes to any specifications without further notice for performance, reliability, production technique and other considerations, VARITRONIX does not assume any liability arising out of the application or use of products herein. Please see Limited Warranty in the previous section.

“Varitronix Limited reserves the right to change this specification.”

Tel: (852) 2197-6000

Fax: (852) 2343-9555.

URL: <http://www.varitronix.com>

- END -